

2. DIMENSIONS AND SPECIFICATIONS

1) 037S Dimensions

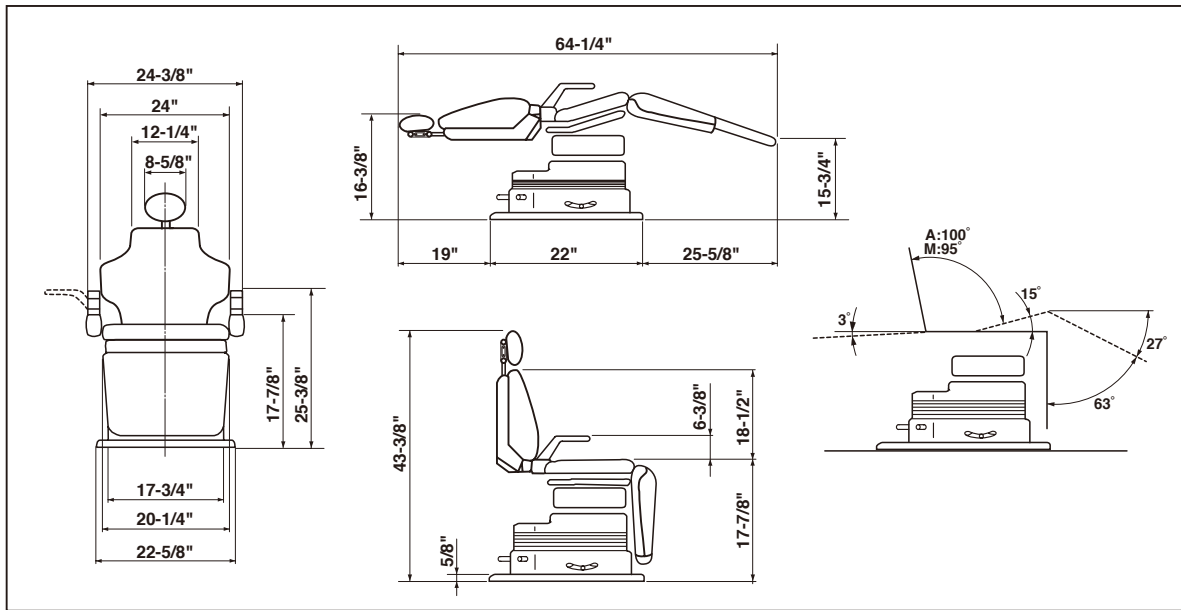

2) 039 Dimensions

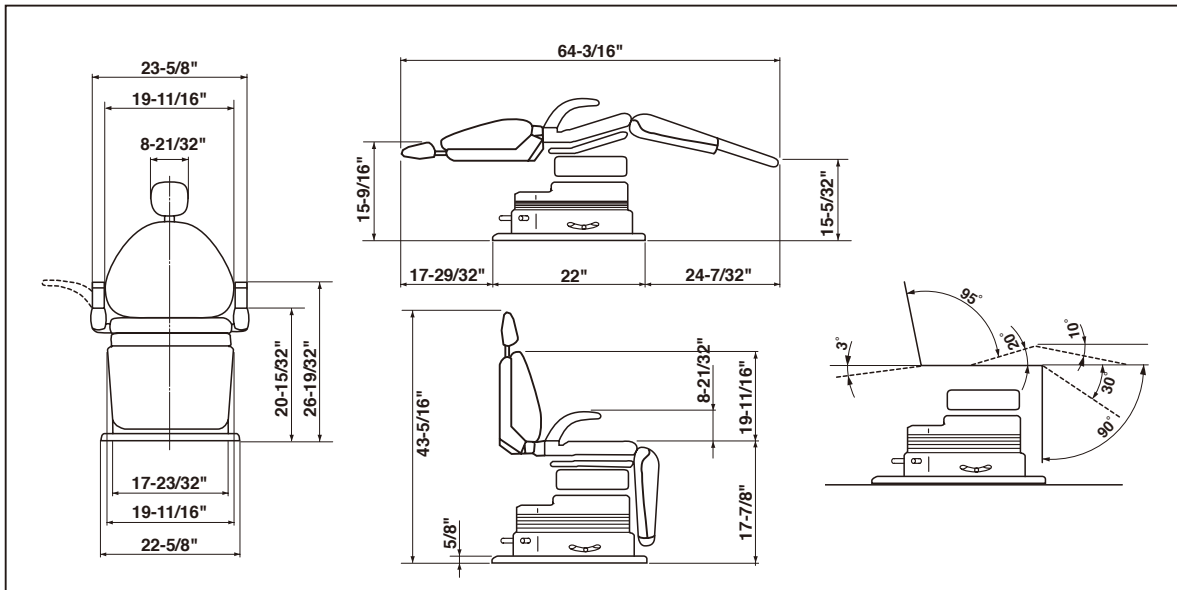

3) Specifications

CHAIR WEIGHT	-----	330 lbs (037S) / 339 lbs (039)
MAXIMUM LOAD	-----	300 lbs
BASE DIMENSION	-----	22" x 22-5/8" x 5/8"
INITIAL HEIGHT	-----	17-7/8"
SEAT ELEVATION STROKE	-----	10-1/4"
HEADREST EXTENSION	-----	4-23/32" (039)
LEGREST EXTENSION	-----	9-1/16"
ROTATION	-----	220 Degree Total (110 Degree. Left & Right)
MOTOR PUMP	-----	Type 5LP
PUMPING CAPACITY	-----	0.72 L/min. (0.19 gal/min)
HYDRAULIC FLUID	-----	900 cc (30 fl.oz)10W Non Detergent Hydraulic Oil
POWER REQUIRED	-----	115V 50 / 60Hz 5.7 / 3.6 A